

Filter Schedule

Quantity	Size	Model	Eff.	P. Drop

Cranking Mechanism Illustration (top & bottom)

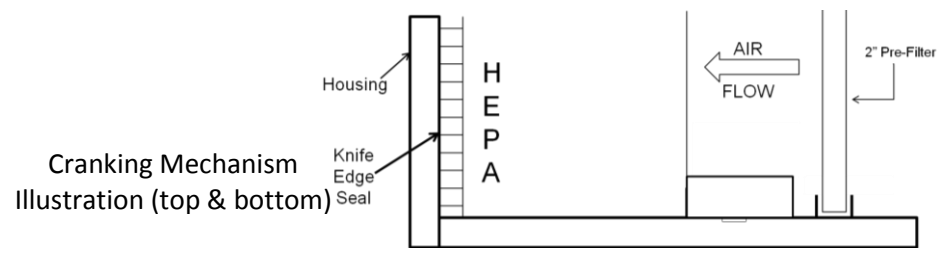

**Options:**

- Stainless Steel Body
- Insulated
- 200\_\_-AF Gauge
- Painted
- Knife Edge Seal
- Other \_\_\_\_\_
- Other \_\_\_\_\_

**Notes:**

- Housings are factory assembled and manufactured from 14 gauge welded galvanized steel.
- Standard unit uses gasketed HEPA on downside.
- Pre-Filter track option is made from galvanized steel. HEPA **requires knife edge**.
- Housing Weight: \_\_\_\_\_ lbs. (less filter)
- Housing Depth: \_\_30" (without Pre-Filter) \_\_33" (with Pre-Filter) Other: \_\_\_\_\_ Inches
- Overall dimensions account for 1 1/2" flanges.
- CAM/Crank filter locking mechanism (see illustration)

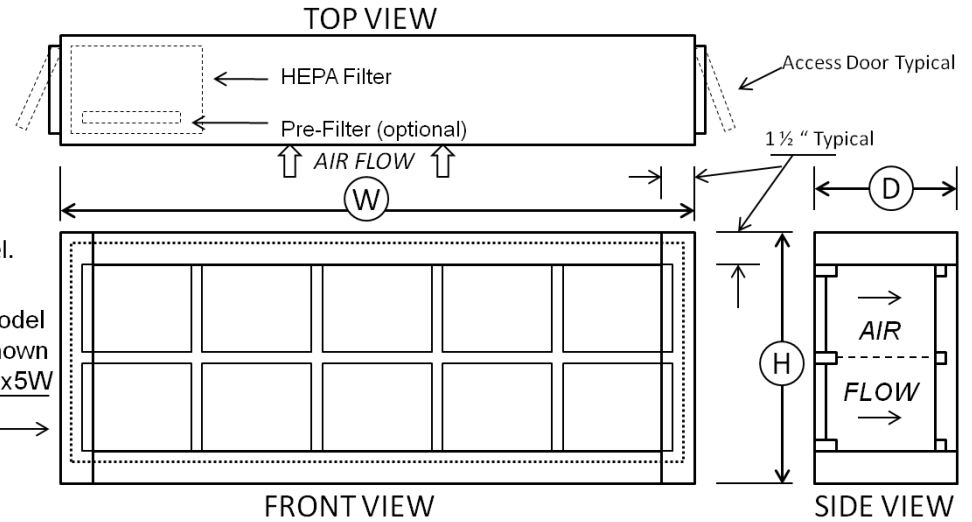

TAG: \_\_\_\_\_

**HEPA Crank Lock Housing Code**

Width Code (# of filters)	1	1 1/2	2	2 1/2	3	3 1/2	4	4 1/2	5	5 1/2
Width Inches (W)	24	36 1/8	48 1/8	60 1/8	72 1/8	84 1/4	96 1/4	108 1/4	120 1/4	132 1/4

Height Code	Height Inches (H)												
1/2	15 1/4												
1	27 1/4												
1 1/2	39 1/4												
2	51 1/4												
2 1/2	63 1/4												
3	75 1/4												
3 1/2	87 1/4												
4	99 1/4												

Side Access Housing

**SUBMITTAL**

**Model "HC"**



Project: \_\_\_\_\_

HVAC Mech: \_\_\_\_\_